

Speed Scene Wiring Frequently Asked Questions

[FAQ](#)

Is it important to follow any particular order when installing my harness?

Yes. Starting at the engines intake manifold, install the Injector connectors and TPS, CTS, MAP.

This helps keep the harness in place while completing your installation. The order of installation of the non-engine connectors depends on your application.

[FAQ](#)

What happens if I have a short in the power supply?

The quick burn fuseable 30 amp link should protect the harness in the event of a short. You must confirm that is no short in your vehicle, before proceeding. Never jump or bypass around the fuseable link. This could damage your harness. Use proper diagnosis and repair techniques on the fuseable link. If you find that you are shorting out / blowing fuses check and make sure that you have not pinched a power wire to a ground.

[FAQ](#)

Where can I purchase the GM Service Manual?

You can order a service manual by calling Helm's at 800- 782-4356. They are the only source for the correct book.

[FAQ](#)

Where can I find professional help with my harness installation?

Speed Scene Wiring can normally assist you over the phone in the installation of your harness. Additionally, Speed Scene Wiring has superior knowledge dealing with the latest in fuel injection technology.

[FAQ](#)

Do you have technical assistance available?

Yes, technical assistance is available. Call Speed Scene Wiring at 210-651-1895.

[FAQ](#)

What should I do if I accidentally split or chafe a wire?

The wire need's to be stripped back roughly 1/2in on each side, slide heat shrink over the wire, twist the copper wire together and apply solder. The next step will be to heat up the heat shrink, then close it up and call it a day or night.

[FAQ](#)

If I break a plug or connector, what should I do?

Call Speed Scene Wiring and we will be happy to supply you with the appropriate pigtail.

[FAQ](#)

How much Voltage should I have?

You should have 12-13 Volts of direct current, coming from the power supply.

[FAQ](#)

Do I need my old harness?

No, although its helpful to save the old connector ends, in case of accidental damage to your new harness.

[FAQ](#)

Where can I find the trouble code references? They are included in our installation instructions.

LT1
Harness Installation Manual

1. Place the harness on the intake, start connecting the injector connectors, this will help hold the harness in place.
2. You will see a number on the reverse side of the injector connector. This distinguishes what cylinder the connector belongs to (2,4,6,8 passenger side and 1,3,5,7 driver side).
3. The Distributor connector will plug in next. This routes on the passenger side, Past the front of the intake and straight down to the distributor. A=RED/BLK
B=PURPLE/WHITE, C=RED, D=PNK/BLK.
NOTE: The distributor has a jumper, the jumper sits between injectors 4 and 6 on the passenger side. You will find that the colors are the same as A-D on line # 3.
4. Coil (gray and black connector with 3-4 male pins) - Plug driver side coil connector into coil pack harness. On the Corvette the coil assembly is located on the passenger side.
5. Air Pump (black connector, white lock and purple seal, 3 wire) This is used to pump air into the exhaust on cold start-up. When the engine is cold the hydrocarbons are very high. Oxygen is pumped into the exhaust manifold to help continue combustion by doing this it lowers hydrocarbon (HC) emissions in the exhaust. Hydrocarbons are made up of two parts; hydrogen and carbon. During combustion, combined with oxygen produces the unburned fuel known as hydrocarbons. A=RED, B=RED, C=BLK.
6. The Manifold Absolute Pressure (MAP) (green plug with a purple waterproof rubber seal) measures the change in the intake manifold pressure from engine load and speed changes and sends optimal adjustments to the computer. Connect the MAP sensor connector on the harness to the sensor located around the frontal section of the intake manifold, of the passenger side. A=BLK, B=GRN, C=GREY.
7. Knock Sensor Connector (KS) (black connector with a blue wire) - KS sensor is a dedicated input signal, detecting engine detonation. The PCM retards Ignition Control (IC) spark timing, based upon the amplitude and frequency of the KS signal being received. If a knock is detected, the computer will automatically retard the timing. This connector routes out on the far right. **Note : Corvette engines have two knock sensors, the Camaro/FireBird electronics only use one.**
8. Exhaust Gas Recirculation (EGR) (black connector with grey waterproof rubber seal) - The EGR must be used when running full emissions on 1974 & later models. The EGR lowers combustion chamber temperatures by eliminating Oxides of Nitrogen (NOx), one of the pollutants found in the engine exhaust. A=PNK, B=GREY.
9. Throttle Position Sensor (TPS) (black connector with purple waterproof rubber seal)

- The TPS returns a proportional voltage to the computer that relates to the angular position of the throttle plates. At idle, the throttle position is between .45-.65V. A wide open throttle-shows high voltage around 4.8V. A=GRY, B=BLK, C=BLUE.

10. Idle Air Control Valve (IACV) (black connector with blue waterproof rubber seal) - Computer controlled stepper motor, which adjusts the engine idle at different loads. A=LT BLU/WHT, B=LT BLU/BLK, C=LT GRN/WHT, D=LT GRN/BLK.

11. Coolant Temp Sensor Wire (ECT) - The coolant temp sensor returns proportional voltage to the computer that relates to the coolant temperature. Cold is high voltage and hot is low voltage its a basic thermister. The sensor is located on the lower left side of the water pump. A=BLK, B=YEL.

12. Canister Purge Plug (CPP) (red connector with light blue waterproof seal) - The CPP is used on full Emissions vehicles. The Computer controls a solenoid that permits manifold vacuum to purge fuel vapors out of the canister. A=RED, B=DK GRN/WHT.

13. Anti-Theft - The Anti-Theft module simulates the passkey signal.

14. Assembly Line Diagnostic Link (ALDL) - Connector is used in conjunction with the check engine light for testing and troubleshooting. You will also notice the light on the right hand side of the connector, that's the check engine light.

15. Fuel Pump Relay - Starts fuel pump with ignition on/run the relay is energized for 2 seconds, this is enough time to pre-load the injectors. Located by the computer tailed out embodied in a 5 pin female connector but only 4 are used. A=GRY, B=BLK/WHT, C=DKGRN/WHT, E=ORN

16. Brake Light Switch Wire (PPL) - This wire must have 12 volts all the time, except when you step on the brake. This will take the torque converter out of lock-up. Use GM switch # 25524845. This only applies if you are running a Automatic Transmission(4L60). If you don't remember what you are running look on the SSW invoice.

17. Check Engine Light - It will be mounted as a permanent fixture on the ALDL and used as a diagnostic aid. The wire is hot when the key is in start or run.

18. Tach Wire (if desired) (white) - Feeds a positive pulse to tachometer. If the Tach wire fails to operate the gauge, contact Speed Scene Wiring at 210-651-1895, for an alternate pulse signal simulator. **Note: When using an Autometer Tachometer. You need to cut the 4 cylinder wire (brown) and the 6 cylinder wire (orange), in order for the tach to work.**

19. Battery Power Wire (ORN) -12V constant, all the time. The Battery wire connects

to the main post on positive side of starter. This wire is protected with fuseable link. This terminal is flat with blue spongy insulation. **Note: This wire will not be with the other group of wires tailed out by the computer.**

20. Park/Neutral Position Wire (PNP) (ORN/BLK) - Switch indicates to the PCM when the transmission is in park, neutral, or drive. This information is used for the EGR and IAC valve operation. This only applies if you are running an Automatic Transmission (4L60). If you don't remember what you are running look on the SSW invoice.

21. Electric Speedometer Wire (DK GRN/WHT) - This wire will operate the speedometer. If problems arise contact Speed Scene Wiring. This is a filtered signal from the computer and may not work on some conversions..

22. Electric Fuel Pump Wire (GRY) - Provides 12V to the fuel pump. A fuel pump relay is provided with the harness and is energized/de-energized by the ECM. This wire connects to the positive (+) symbol on the pump, and the other terminal with the negative (-) symbol, will be placed to the frame. By placing this to the frame you complete the ground circuit and the pump will operate like it was intended.

23. Ignition Power - The ignition wires must be connected to a 12V power supply, with the key in START (crank) and RUN position. 12V will be distributed through the computer (ECM), injectors and coil.

24. Engine Ground Lug (BLK/WHT wire) - The ground system is curtail for proper operation. A good battery to motor and motor to harness ground is a must.

25. Alternator (Red or Brown)- You can use a 12 Volt dash bulb with ignition power on the other side of the bulb. This wire can also connect to a 500 OHM ¼ watt resistor and then place to ignition power. What this does is supply the adequate power to the rectifier bridge, allowing the alternator to start charging.

26. A/C Compressor (Dk Green)- Connect to the wire that originally powered the old compressor. This will engage the idle up feature, under load.

27. Vehicle Speed Sensor Plug (VSS) (black connector with blue waterproof rubber seal) - The VSS is a pulse counter type input that informs the PCM how fast the vehicle is being driven. The VSS system uses an inductive sensor mounted in the tail housing of the transmission and a 40-toothed reluctor wheel on the tail shaft. As the reluctor rotates, the teeth alternately interfere with the magnetic field of the sensor creating an induced voltage pulse in Alternating Current that comes out to 40 pulses per mile (AC). Once the computer receives this signal the transmission will shift correctly. This refers to all full emissions harnesses with automatic (4L60) transmissions. A=YEL, B=PPL.

28. Oxygen Sensor(B1S1) (passenger side) (solids) - One wire PPL

29. Oxygen Sensor(B2S1) (driver side) (stripes) - One wire PPL/WHT

B1S1= This means left bank one sensor one for the front oxygen sensors. Solids.

B2S1=Bank two sensor one is the passenger side (right) front oxygen sensor. With stripes.

Just remember, stripes on the left (driver) and solids on right (passenger).

30. Intake Air Temp Sensor Plug (IAT) (grey connector with light blue waterproof rubber seal) - The IAT operates in the same fashion as the coolant temp sensor, except it relates to the air temp entering the plenum. A=BLK, B=TAN

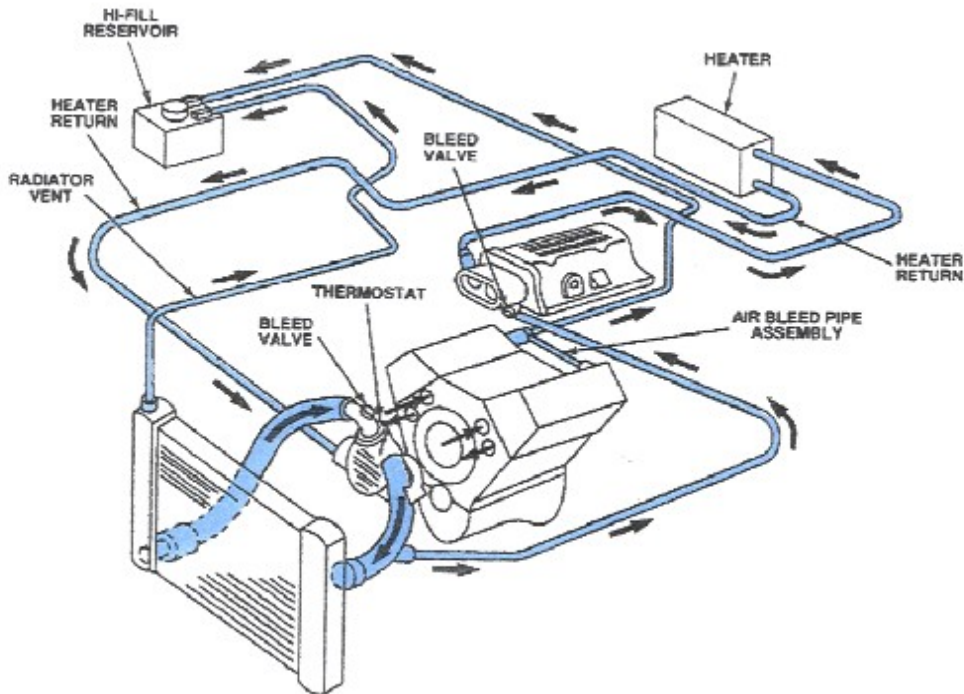

Conventional LT1/LT4 Reverse Cooling System